

**RIFTEK**  
Sensors & Instruments



## **BACK-TO-BACK DISTANCE MEASURING GAUGE**

**IMR-L Series**

### **User's manual**

22, Logoisky tract, Minsk  
220090, Republic of Belarus  
tel/fax: +375 17 281 35 13  
info@riftek.com  
www.riftek.com

## Contents

|       |  |    |
|-------|--|----|
| 1.    | Safety precautions and measurement conditions.....                 | 3  |
| 2.    | Electromagnetic compatibility .....                                | 3  |
| 3.    | Laser safety .....   | 3  |
| 4.    | General information .....  | 3  |
| 5.    | Basic data and performance characteristics.....                    | 4  |
| 6.    | Complete set to be supplied .....                                  | 4  |
| 7.    | Design .....   | 4  |
| 8.    | Operation principle .....  | 5  |
| 9.    | Working with the gauge .....                                       | 5  |
| 9.1.  | Gauge turn-on .....  | 5  |
| 9.2.  | Single measurement .....   | 5  |
| 9.3.  | Measurement with averaging .....                                   | 5  |
| 9.4.  | Gauge turn-out .....   | 5  |
| 10.   | Indication parameters setup .....                                  | 6  |
| 10.1. | Image brightness set-up.....                                       | 6  |
| 10.2. | Millimeters-Inches display set-up .....                            | 6  |
| 11.   | Service operation modes.....                                       | 6  |
| 11.1. | Calibration conditions .....                                       | 6  |
| 11.2. | Get into operational modes .....                                   | 7  |
| 11.3. | Calibration of the sensor zero .....                               | 7  |
| 12.   | Charging of built-in accumulator battery .....                     | 8  |
| 13.   | Warranty policy.....   | 8  |
| 14.   | Distributors .....   | 8  |
| 15.   | Annex 1. RIFTEK measurement instruments for railway transport..... | 10 |

## 1. Safety precautions and measurement conditions

- The metering accuracy depends greatly on the wheel surface quality. Therefore it is necessary to carry out the check and presorting of the wheel surface roughness and flaws before measuring the diameter.
- Prior to place the gauge is a need to clean the wheels parts that contact with gauge and the place of laser beam hit.
- At arranging the gauge, do not allow hitting its supports on the wheel
- It is necessary to inspect the gauge supports periodically and to cleanse them
- To save the battery power the display extinguishes if there were no buttons pressings for 60 seconds, at that only blinking dot is shown. Pressing any button just turns on the display and does not act in any other way in this case.

## 2. Electromagnetic compatibility

The back-to-back distance measuring gauge (IMR Series) has been developed for use in industry and meets the requirements of the following standards:

- EN 55022:2006 Information Technology Equipment. Radio disturbance characteristics. Limits and methods of measurement.
- EN 61000-6-2:2005 Electromagnetic compatibility (EMC). Generic standards. Immunity for industrial environments.
- EN 61326-1:2006 Electrical Equipment for Measurement, Control, and Laboratory Use. EMC Requirements. General requirements.

## 3. Laser safety

The device make use of an c.w. 660 nm wavelength semiconductor laser. Maximum output power is 1 mW. According to IEC 60825-1:2007 the device belong to the 2 laser safety class. The following warning label is placed on the laser body:

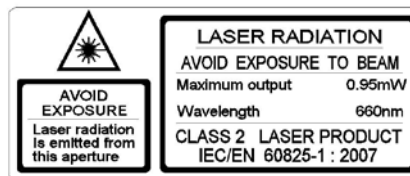

The following safety measures should be taken while operating the IMR:

- Do not target laser beam to humans;
- Do not disassemble the laser scanning module;
- Avoid staring into the laser beam.

## 4. General information

Gauge is designed for measuring back-to-back distance of railway, metro and tram wheels in the course of checkup, examination, repair and formation of wheel sets. Measurements are made directly on rolling stock without wheel set roll-out.

## 5. Basic data and performance characteristics

| Name of parameter         | Value                              |
|---------------------------|------------------------------------|
| Measurement range, mm     | 1300...1500 or on request          |
| Measurement error, mm     | $\pm 0,3$                          |
| Indication discreteness   | 0.1mm, 0.01mm * or 0.01 inch       |
| Display                   | build-in, LED                      |
| Operating temperature, °C | -5...+40                           |
| Weigh, kg                 | 1                                  |
| Dimensions                | figure 1                           |
| Power supply              | rechargeable batteries 2xAAA, 1.2V |

## 6. Complete set to be supplied

| Name  | Quantity   |
|---|------------|
| Back-to-back distance measuring gauge, IMR series | 1 piece    |
| Charger   | 1 piece    |
| Manual  | 1 piece    |
| Case  | 1 piece    |
| Calibration tools (option)                        | on request |

## 7. Design

The gauge (fig.1) contains magnetic support to place the gauge onto the internal surface of the wheel.

There are a digital numeric display and control buttons on the front panel of the gauge. Output window for laser radiation, input window, indication of bluetooth connection, "Charge" connector for charging device connection are placed on the top panel of the gauge.

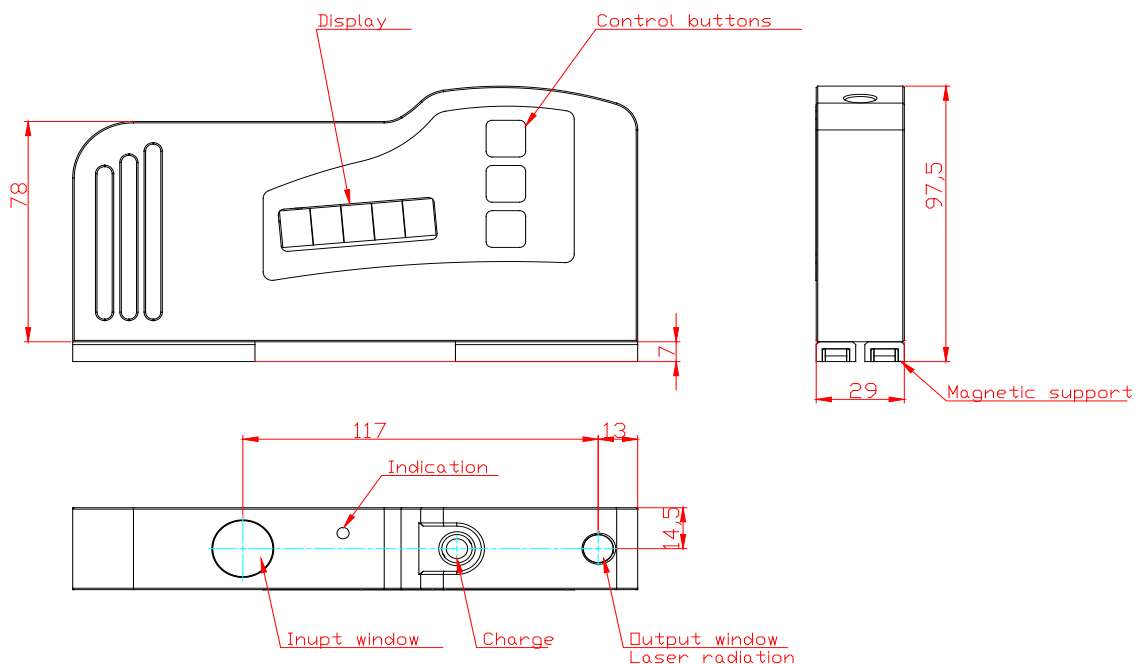

Figure 1

## 8. Operation principle

The method of back-to-back distance measurement is based on the direct measurement the distance by laser triangulation sensor in-built onto the gauge.

## 9. Working with the gauge

### 9.1. Gauge turn-on

Press **Red** button to turn on the power. The display shows “ErrP” message if the accumulator battery voltage became lower than the control level.

### 9.2. Single measurement

To perform measurement, it is necessary to:

- turn the power on (press **Red** button). The display shows “- - - -”;
- place the gauge on the inner surface of the wheel;
- make sure that the magnetic support is tight against the surface of the wheel;
- press **Green** button.
- in a 1 second the display will show the value back-to-back distance.

For viewing the result of measurement with indication discreteness of **0.01mm** (it is accessible only in a mode of direct indication) it is necessary to press **Blue** button, thus displayed result will be shifted to the left on one digit. Next pressing **Blue** button will lead to return of indication to a starting position:

### 9.3. Measurement with averaging

The program of the back-to-back distance calculation contains an averaging algorithm that allows eliminating the surface defects influence on the distance measuring result. All the results of metering, performed after the **Red** button pressing, are averaged. The measurement is meant to be **Green** button pressing.

To carry out measurements it is necessary to

- turn the power on (press **Red** button). The display shows “- - - -”;
- place the gauge;
- make sure the magnetic support is tight against the inner surface of the wheel;
- press **Green** button;
- display shows the value of pressing counter “n x”, where **x** – quantity of averaged values;
- in a 1 second display shows an average value of the back-to-back distance;
- move the gauge to a new position and repeat the measuring.  
(The total quantity of measurements averaged in this way can run up to 9999.)
- Press **Red** button to reset averaging result at switching to another wheel.

For viewing the result of measurement with indication discreteness **0.01mm** (it is accessible only in a mode of direct indication) it is necessary to press **Blue** button, thus displayed result will be shifted to the left on one digit. Next pressing **Blue** button will lead to return of indication to a starting position.

### 9.4. Gauge turn-out

The gauge turn-out occurs automatically. The display extinguishes if there were no button pressings for 60 seconds, at that only blinking dot is shown. If there were no button pressings for 4 more minutes, the gauge is turned out completely. You can turn the gauge off by long pressing **Red** button (more than 3 sec.).

## 10. Indication parameters setup

### 10.1. Image brightness set-up

To change the display brightness it is necessary to:

- turn the power on (press **Red** button);
- press **Blue** button and keep it pressed for more than three seconds;
- display will show “Up”;
- press **Blue** button one more time, the image brightness set-up will be displayed “brt”;

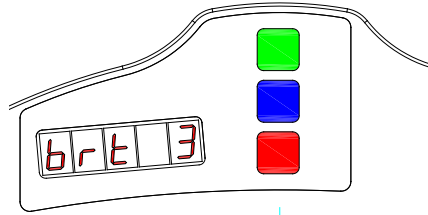

- choose the necessary brightness value by **Green** button pressings;
- to save the changed parameters press **Red** button the display shows “SAUE” message, press the **Green** button to confirm saving and **Red** to cancel saving of the changed parameters;

At brightness choosing one should take into account that increased brightness enhances power consumption and decreases the period till battery recharge moment.

### 10.2. Millimeters-Inches display set-up

To change the mode it is necessary to:

- turn the power on (press **Red** button);
- press **Blue** button and keep it pressed for more than three seconds;
- display will show “Up”;
- press **Blue** button again until the either “SI” or “Inch” message appears on the display. “SI” – measuring results will be shown in mm, “Inch” – measuring results will be shown in inches;
- choose the necessary value by **Green** button pressings;
- to save the changed parameters press **Red** button the display shows “SAUE” message, press the **Green** button to confirm saving and **Red** to cancel saving of the changed parameters

**NOTE:** Discreteness of inch indication is two digits after point. The separation point is indicated at the top side of the screen in the reverse indication regime

## 11. Service operation modes

This section contains the description of the modes for the check of device efficiency and calibration. As erroneous actions in this mode can lead to invalid measurement results, only specially trained personnel should perform such operations.

### 11.1. Calibration conditions

**Calibration of the device is not necessary in the current work. It is necessary only after producing, repairing and also after checking with negative result.**

To perform calibration the following means are necessary:

- Calibration tool RF260.90.000 fig.2;

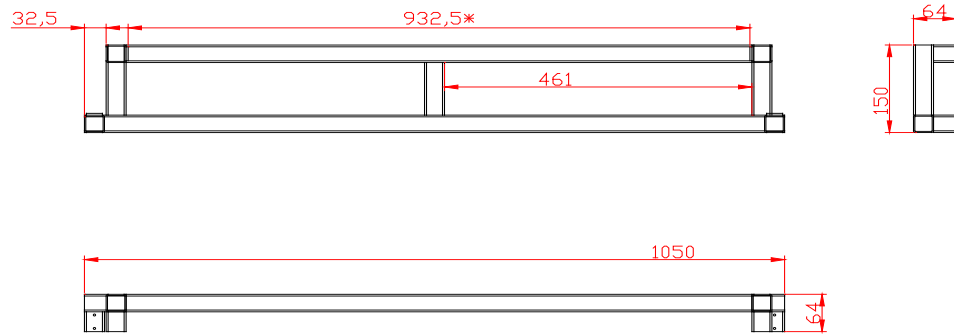

**Figure 2**

\* - the length of calibration tool is checked with accuracy of 0,01 mm.

## 11.2. Get into operational modes

- To get into the operational modes it is necessary to turn-off the device (press **Red** button more then 3 seconds).
- Keeping **Green** button in pushed position turn-on the device (press **Red** button).
- Display shows “CLbr.0” message (the mode of calibration of the sensor's "0").
- To get into this mode press **Green** button (see. p.11.3).
- To get out the mode of calibration press **Red** button.

## 11.3. Calibration of the sensor zero

- Zero calibration mode being enabled, the display shows the length of calibration tool.
- If editing of the lenth value is not required, go to the next step. To edit the length value, press the **Blue** button, and the digit to be edited starts blinking. Changing over between the digits is made by pressing the **Blue** button while changing of values is made by pressing the **Green** button. When editing is finished, press the **Red** button and confirm or cancel saving of the parameter by pressing the **Green** button or **Red** button, respectively.
- Press the **Green** button, and the length value starts blinking, which means that the device must be placed onto calibration tool. The magnetic support of the gauge must be tightly fitted to the flat plates of calibration tool.
- Press the **Green** button, and the display shows current reading of the sensor in it own coordinate system.

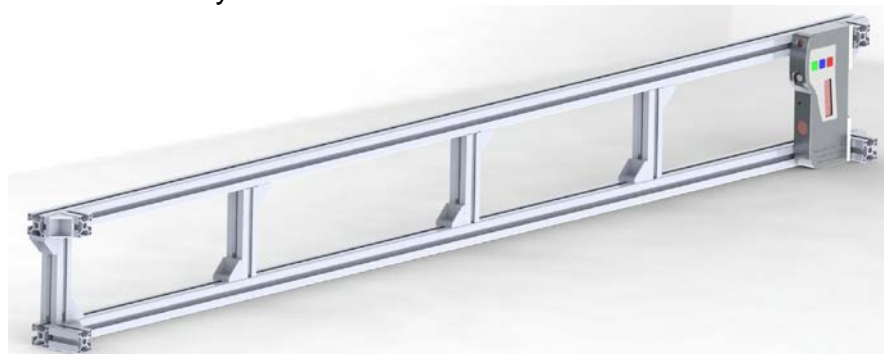

**Figure 3**



- If readings of the sensor are sufficiently stable, press the **Blue** button. Sensor zero position is calculated in the device coordinate system, and prompt appears to save calibration results. Press the **Green** or **Red** button to confirm or cancel saving of the results, respectively.

## 12. Charging of built-in accumulator battery

To charge accumulator battery it is necessary to connect charging device to the power grid 85-250V and to a battery compartment on the top panel of the gauge.

The period of charging is 15 hours.

## 13. Warranty policy

Warranty assurance for the Back-to-back measurement gauge IMR-L Series - 24 months from the date of putting in operation; warranty shelf-life - 12 months.

## 14. Distributors

|  |   |   |
|--|---|---|
| <p><b>AUSTRALIA</b></p> <p><b>XN Innovation</b><br/>           LG Centre, Suite 1, Level M, 55 Par-<br/>           ramatta Rd,<br/>           NSW, 2141, Lidcombe, Australia<br/>           Tel: +61 (0)2 8091 2426<br/>           Fax: +61 (0)2 9648 6597<br/> <a href="mailto:xni.sales@gmail.com">xni.sales@gmail.com</a></p>   | <p><b>BENELUX</b></p> <p><b>Altheris B.V.</b><br/>           Scheveningsweg 15<br/>           2517 KS The Hague,<br/>           The Netherlands<br/>           Tel: +31 (70) 3924421<br/>           Fax: +31 (70) 3644249<br/> <a href="mailto:sales@altheris.nl">sales@altheris.nl</a><br/> <a href="http://www.altheris.com">www.altheris.com</a></p>   | <p><b>BULGARIA, HUNGARY</b></p> <p><b>RMT Ltd.</b><br/>           R Zahradni 224<br/>           739 21 Paskov, Czech Republic<br/>           Tel: +420 558640211<br/>           Fax: +420 558640218<br/> <a href="mailto:rmt@rmt.cz">rmt@rmt.cz</a><br/> <a href="mailto:lubomir.kolar@rmt.cz">lubomir.kolar@rmt.cz</a><br/> <a href="http://www.rmt.cz">www.rmt.cz</a></p> |
| <p><b>CHINA</b></p> <p><b>Zhenshangyou Technologies Co.,Ltd.</b><br/>           Rm 1806, Block B, Jinhaian Building<br/>           Chuangye Road, Nanshan District<br/>           Shenzhen,518054, China<br/>           Tel: 86)755-26528100/8011/8012<br/>           Fax: (86)755-26528210/26435640<br/> <a href="mailto:info@51sensors.com">info@51sensors.com</a><br/> <a href="http://www.51sensors.com">www.51sensors.com</a></p>                         | <p><b>CZECH REPUBLIC</b></p> <p><b>RMT Ltd.</b><br/>           Zahradni 224<br/>           739 21 Paskov, Czech Republic<br/>           Tel: +420 558640211<br/>           Fax: +420 558640218<br/> <a href="mailto:rmt@rmt.cz">rmt@rmt.cz</a><br/> <a href="mailto:lubomir.kolar@rmt.cz">lubomir.kolar@rmt.cz</a><br/> <a href="http://www.rmt.cz">www.rmt.cz</a></p>  | <p><b>GERMANY</b></p> <p><b>Disynet GmbH</b><br/>           Westwall 12<br/>           D-41379 Brueggen, Germany<br/>           Tel: +49 (2157) 8799-0<br/>           Fax: +49 (2157) 8799-22<br/> <a href="mailto:disynet@sensoren.de">disynet@sensoren.de</a><br/> <a href="http://www.sensoren.de">www.sensoren.de</a></p>   |
| <p><b>GERMANY</b></p> <p><b>BIP-Industrietechnik GmbH</b><br/> <b>RAILWAY INSTRUMENTS ONLY</b><br/>           Am Elisabethhof 22,<br/>           D-14772 Brandenburg<br/>           D-41379 Brueggen, Germany<br/>           Tel: +49 (0) 33 81 75 90 0<br/>           Fax: +49 (0) 33 81 75 90 11<br/> <a href="mailto:info@bip-industrie.de">info@bip-industrie.de</a><br/> <a href="http://www.bip-industrietechnik.de">www.bip-industrietechnik.de</a></p> | <p><b>INDIA</b></p> <p><b>Pragathi Solutions</b><br/>           #698, 5th Main, 8th Cross,<br/>           HAL 3rd Stage,<br/>           New Tippasandra Road,<br/>           Bangalore, 560075, India<br/>           Tel: +91 80 32973388<br/>           Tel/fax: +91 80 25293985<br/>           Mobile: +91 9448030426/<br/>           +919448492380<br/> <a href="mailto:sales@pragathisolutions.in">sales@pragathisolutions.in</a><br/> <a href="mailto:arghya@pragathisolutions.in">arghya@pragathisolutions.in</a><br/> <a href="http://www.pragathisolutions.in">www.pragathisolutions.in</a></p> | <p><b>INDONESIA</b></p> <p><b>PT. DHAYA BASWARA SANIYASA</b><br/>           Sentra Niaga Puri Indah Blok T6<br/>           No. 41 Kembangan<br/>           Jakarta,11610, Indonesia<br/>           Tel: 021 5830 4517<br/>           Fax: 021 5830 4518<br/> <a href="mailto:management@ptdbs.co.id">management@ptdbs.co.id</a></p>   |



|  |  |   |
|--|--|---|
| <p><b>ITALY</b></p> <p><b>FAE s.r.l.</b><br/>Via Tertulliano, 41<br/>20137 Milano, Italy<br/>Tel: +39-02-55187133<br/>Fax: +39-02-55187399<br/><a href="mailto:fae@fae.it">fae@fae.it</a><br/><a href="http://www.fae.it">www.fae.it</a></p>   | <p><b>FINLAND</b></p> <p><b>TERÄSPYÖRÄ-STEELWHEEL OY</b><br/><b>RAILWAY INSTRUMENTS ONLY</b><br/>Juvan teollisuuskatu 28<br/>FI-02920 ESPOO, Finland<br/>Tel: +358 400 422 900<br/>Fax: +358 9 2511 5510<br/><a href="mailto:steelwheel@steelwheel.fi">steelwheel@steelwheel.fi</a><br/><a href="http://www.teraspyora.fi">www.teraspyora.fi</a></p> | <p><b>LITHUANIA</b></p> <p><b>JSC "Comexim"</b><br/>Serbentu, 222, LT-5419<br/>Siauliai, Lithuania<br/>Tel/Fax:+370 41553487<br/><a href="mailto:comexim@siauliai.aiva.lt">comexim@siauliai.aiva.lt</a><br/><a href="http://www.komeksimas.lt">www.komeksimas.lt</a></p>  |
| <p><b>MALAYSIA</b></p> <p><b>OptoCom Euiptech (M) Sdn Bhd</b><br/>H-49-2, Jalan 5, Cosmoplex<br/>Industrial Park. Bandar Baru Salak<br/>Tinggi, Sepang, Malaysia<br/>Tel: 603 8706 6806<br/>Fax: 603 8706 6809<br/><a href="mailto:optocom@tm.net.my">optocom@tm.net.my</a><br/><a href="http://www.optocom.com.my">www.optocom.com.my</a></p> | <p><b>POLAND</b></p> <p><b>P.U.T. GRAW Sp. z o.o.</b><br/>ul. Karola Miarki 12, skr.6.<br/>44-100 Gliwice, Poland<br/>Tel/fax: +48 (32) 231 70 91<br/><a href="mailto:info@graw.com">info@graw.com</a><br/><a href="http://www.graw.com">www.graw.com</a></p>  | <p><b>POLAND</b></p> <p><b>MTL ASCO Sp. z o.o.</b><br/><b>RAILWAY INSTRUMENTS ONLY</b><br/>ul. Wielowiejska 53<br/>44-120 PYSKOWICE (k/ GLIWIC),<br/>Poland<br/>Tel: +48 32 233 33 33<br/>Fax: +48 32 233 21 34<br/><a href="mailto:serwis@mtlasco.pl">serwis@mtlasco.pl</a><br/><a href="http://www.ascorail.pl">www.ascorail.pl</a></p>                         |
| <p><b>POLAND</b></p> <p><b>RMT Ltd.</b><br/>Zahradni 224<br/>739 21 Paskov, Czech Republic<br/>Tel: +420 558640211<br/>Fax: +420 558640218<br/><a href="mailto:rmt@rmt.cz">rmt@rmt.cz</a><br/><a href="mailto:lubomir.kolar@rmt.cz">lubomir.kolar@rmt.cz</a><br/><a href="http://www.rmt.cz">www.rmt.cz</a></p>                                | <p><b>PORTUGAL</b></p> <p><b>UltraSens</b><br/>Qt. da Portela, Lt. 22.1, Ap. 152<br/>3030 - 502 Coimbra, Portugal<br/>Phone +351 239 796 277<br/>Fax: +351 239 918 267<br/><a href="mailto:info@ultrasens.com">info@ultrasens.com</a><br/><a href="http://www.ultrasens.com">www.ultrasens.com</a></p>   | <p><b>RUSSIA</b></p> <p><b>Sensorika-M LLC</b><br/>Dmitrovskoye shosse 64-4<br/>127474, Moscow, Russia<br/>Tel: 487-0363<br/>Fax: 487-7460<br/><a href="mailto:info@sensorika.com">info@sensorika.com</a><br/><a href="http://www.sensorika.com">www.sensorika.com</a></p>  |
| <p><b>RUSSIA</b></p> <p><b>Intellect-Optic</b><br/>Ekaterinburg Mira str 32 – 120<br/>Tel/fax: 343 2227565<br/>Tel/fax: 343 2227370<br/><a href="mailto:pesterev@d-test.ru">pesterev@d-test.ru</a><br/><a href="http://www.d-test.ru">www.d-test.ru</a></p>  | <p><b>SERBIA, SLOVAKIA</b></p> <p><b>RMT Ltd.</b><br/>Zahradni 224<br/>739 21 Paskov, Czech Republic<br/>Tel: +420 558640211<br/>Fax: +420 558640218<br/><a href="mailto:rmt@rmt.cz">rmt@rmt.cz</a><br/><a href="mailto:lubomir.kolar@rmt.cz">lubomir.kolar@rmt.cz</a><br/><a href="http://www.rmt.cz">www.rmt.cz</a></p>                            | <p><b>SOUTH KOREA</b></p> <p><b>PROSEN. CO., LTD</b><br/>211/ Jung-woo Venture 2, 1228-1<br/>Singil-dong, Danwon-gu,<br/>Ansan-si, Gyeonggi-do, 425-839<br/>Republic of Korea<br/>Tel: +82-(0)31-508-3456~7<br/>Fax: +82-(0)31-624-3458<br/><a href="mailto:prosensor@naver.com">prosensor@naver.com</a><br/><a href="http://www.prosen.kr">www.prosen.kr</a></p> |
| <p><b>SOUTH KOREA</b></p> <p><b>DAESHIN T&amp;S CO., LTD</b><br/>1702 Ace High-End Tower 5<br/>Gasandong, Geumcheon-Gu<br/>Seoul, Korea<br/>Tel: +82-2-2279-8800<br/>Fax: +82-2-2277-6667<br/><a href="mailto:railstar1983@korea.com">railstar1983@korea.com</a><br/><a href="http://www.railstar.co.kr">www.railstar.co.kr</a></p>            | <p><b>SPAIN</b></p> <p><b>Iberfluid Instruments S.A.</b><br/>Cardenal Reig, 12<br/>08028 Barcelona, Spain<br/>Tel: +34 93 447 10 65<br/>Fax: +34 93 334 05 24<br/><a href="mailto:myct@iberfluid.com">myct@iberfluid.com</a><br/><a href="http://www.iberfluid.com">www.iberfluid.com</a></p>  | <p><b>SWEDEN, NORWAY,<br/>DENMARK</b></p> <p><b>BLConsult</b><br/>Rävbergsvägen 31<br/>SE 713 30, Nora, Sweden<br/>Tel: +46 (0) 587 153 20<br/>Mobile: +46 (0) 70 663 19 25<br/><a href="mailto:info@blconsult.se">info@blconsult.se</a><br/><a href="http://www.blconsult.se">www.blconsult.se</a></p>   |

|   |  |   |
|---|--|---|
| <p><b>SWITZERLAND</b></p> <p><b>ID&amp;T GmbH</b><br/>         Gewerbstrasse 12/a<br/>         8132 Egg (Zurich), Switzerland<br/>         Tel: +41 (0)44 994 92 32<br/>         Fax: +41 (0)44 994 92 34<br/> <a href="mailto:info@idtlaser.com">info@idtlaser.com</a><br/> <a href="http://www.idtlaser.com">www.idtlaser.com</a></p>                           | <p><b>TURKEY</b></p> <p><b>MATES A.S.</b><br/> <b>RAILWAY INSTRUMENTS ONLY</b><br/>         Gezegen Sok. N: 10<br/>         GOP ANKARA, TURKEY<br/>         Tel: +90 312 447 2192<br/>         Fax: +90 312 447 2193<br/> <a href="mailto:mates@mates.com.tr">mates@mates.com.tr</a><br/> <a href="http://www.mates.com.tr">www.mates.com.tr</a></p>   | <p><b>UKRAINE</b></p> <p><b>KODA</b><br/>         Frunze st 22<br/>         61002, Harkov, Ukraine<br/>         Tel/fax: +38 057 714 26 54<br/> <a href="mailto:mail@koda.com.ua">mail@koda.com.ua</a><br/> <a href="http://www.koda.com.ua">www.koda.com.ua</a></p>          |
| <p><b>UNITED KINGDOM, IRELAND</b></p> <p><b>Ixthus Instrumentation Ltd</b><br/>         The Stables, Williams' Barns<br/>         Tiffield road, Towcester, Northants<br/>         Tel: 01327 353437<br/>         Fax: 01327 353564<br/> <a href="http://www.ixthus.co.uk">www.ixthus.co.uk</a><br/> <a href="mailto:info@ixthus.co.uk">info@ixthus.co.uk</a></p> | <p><b>USA, CANADA, MEXICO</b></p> <p><b>International Electronic Machines Corporation</b><br/> <b>RAILWAY INSTRUMENTS ONLY</b><br/>         R 60 Fourth Avenue, Albany,<br/>         New York, USA<br/>         Tel: +1 (518) 449-5504<br/>         Fax: +1 (518) 449-5567<br/> <a href="mailto:railway_marketing@iem.net">railway_marketing@iem.net</a><br/> <a href="http://www.iem.net">www.iem.net</a></p> | <p><b>USA, CANADA, MEXICO</b></p> <p><b>Acuity Products of Schmitt Industries, Inc.</b><br/>         2765 NW Nicolai Street<br/>         Portland, OR, 97210, USA<br/>         Tel: +1-503-227-7908<br/> <a href="mailto:sales@acuitylaser.com">sales@acuitylaser.com</a></p> |

## 15. Annex 1. RIFTEK measurement instruments for railway transport

### Laser wheel profilometer. IKP Series

A laser profilometer is designed for the measuring of:

- wheel flange height;
- wheel flange thickness;
- wheel flange slope;
- full profile scanning and analyze of wheel rolling surface;
- maintaining of electronic wear data base;
- control of tolerances and sorting in the course of checkup, examination, repair and formation of railway wheel sets;

Measurements are made directly on rolling stock without wheel set roll-out.



### Portable laser rail profilometer. PRP Series

The main functions of PRP are:

- obtaining the information on the cross-section profile of the working railhead surface;
- full profile scanning and analyze of the railhead acting face;
- visualization of the combined graphical images of actual and new cross-section railhead profiles on the display of system unit.





### Wheel diameter measuring gauge. IDK Series

Electronic gauge is designed for measuring wheel rolling circle diameter of railway, metro and tram wheel sets.

Measurements are made directly on rolling stock without wheel set roll-out.



### Disc brakes profile gauge, IKD Series

Laser disc brakes profilometer IKD Series is designed for disc brakes profile measuring.

The main functions of IKD are:

- obtaining the information on the profile parameters of the working disc brakes surface;
- full profile scanning and analyze of the disc brakes acting face;
- visualization of the combined graphical images of actual and new disc brakes profiles on the display of system unit.