

Wheel Diameter Measuring Gauge

Electronic gauge is designed for measuring wheel rolling circle diameter. Measurements are made directly on rolling stock without wheel set roll-out. The measurement of the diameter is performed according to the "three points" technique, without the complete wheel coverage.

The gauge contains numeric display to show the value of the wheel diameter. IDK-BT gauge contains Bluetooth interface for transfer results into wheel-set wear database management system.



Basic Technical Data

Name of parameter	Value
Measurement range, mm	400...1400 or on request
Measurement error, mm	± 0.2
Indication discreteness	0.1mm, 0.01mm * or 0.01 inch **
Position of measurement, S, mm	On request
Distance between axes of ball bearings (base), mm and measurement range, mm	200 \pm 0.5 (400...950 mm) or 250 \pm 0.5 (600...1400 mm) or 300 \pm 0.5 (720...1400 mm)
Display	build-in, LED
Operating temperature, °C	-5...+40
Power supply – built-in rechargeable battery	two AAA 1,2V
The number of measurements that can be taken before battery recharge is not less than	1000
Weigh, kg	0,5

Overall dimension

Electronic gauge contains two ball supports to place the gauge onto the roll surface, two side magnet supports to base the gauge to the wheel edge and a measuring tip.

There are a digital numeric display and control buttons on the front panel of the gauge. "Charge" connector for charging device connection and Bluetooth indication LED are situated on the top panel of the gauge.

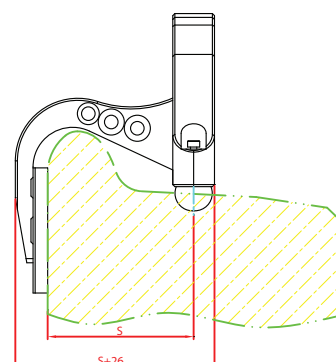
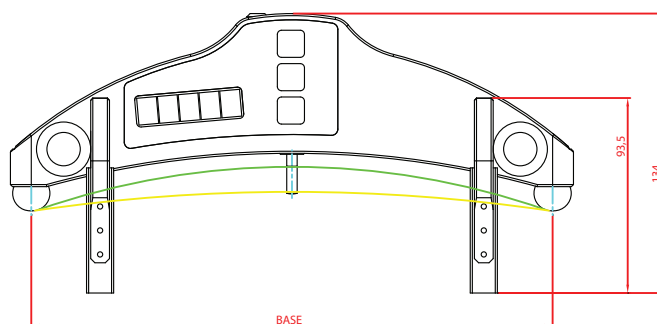

■ Example of item designation when ordering

IDK-S/B-MIN/MAX-X-BT

Symbol	Description
S	Position of measurement, mm
B	Base, mm
MIN	Bottom of measuring range, mm
MAX	Up of measuring range, mm
X	Position of indication. A – Indication is at the side of side supports (figure A), B – Indication is at opposite side (figure B)
BT	Bluetooth presence*

* The gauge with Bluetooth can work in autonomous regime and together with RF303 PDA or PC, with measurements saving in database.
 Example: IDK-70/250-850/1260-A-BT. Position of measurement – 70 mm; base of the gauge – 250 mm; bottom of measuring range – 850 mm; up of measuring range – 1260 mm; position of indication – A, BT – Bluetooth presence.

■ Measurement Instruments for Railway Transport

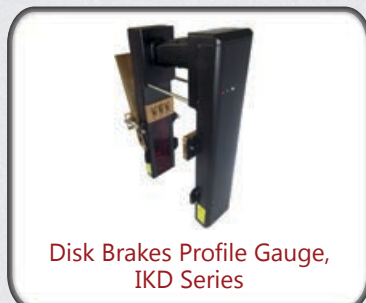

■ Contacts



ISO 9001:2008 Quality System

RIFTEK Ltd.
 22-311, Logoisky tract,
 220090, Minsk,
 Republic of Belarus

Tel/Fax: +375 17 281-35-13
 Email: info@riftek.com
sales@riftek.com
 Site: www.riftek.com